

Overload Detect / Efficiency Meter Board

+/- 18VDC Unreg. can come from PAM or class H modulator boards

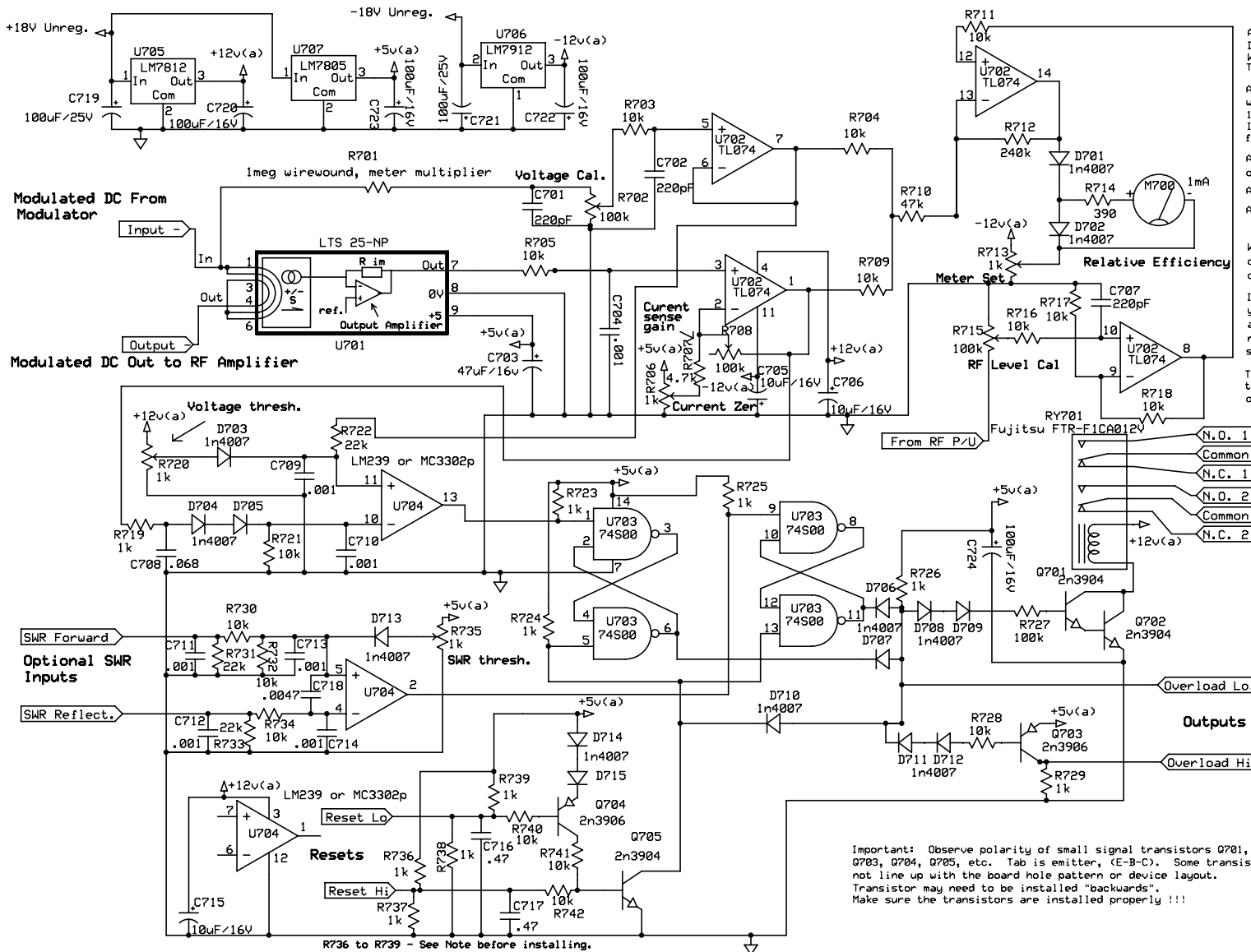

Setup and Adjustments

Adjust R702 (voltage cal) for 3 VDC at U702 pin 7 with DC carrier voltage. Initial setup as follows: With +12vdc at input port, set R702 for .8VDC at U702 Pin 7. This is the approx. setup for 45V Carrier (45V = 3V)

Adjust R706, R708 (current zero, current gain) such that, with normal operating current flowing from modulator, U702 pin 1 reads 3VDC with operating current and 0VDC with no current. Initial Setup: with U702 pin 3 at ground (0V), set R706 & R708 for -10.5VDC at pin 1, and 0VDC when pin 3 is not at ground.

Adjust R720 for 3VDC at U704 Pin 11 in standby (no modulator output).

Adjust R713 - Meter Set for 1/2 scale, xmtr in standby

Adjust R735 (SWR) to midpoint if SWR is not used.

Using the Resets, and Overload Hi and Lo outputs
When either of the reset lines are asserted (reset low = low or reset hi = hi), the board will reset and also enter the overload state - asserting the Overload Lo and Hi outputs.

In general, the Resets should be configured so the reset line you are going to use (Hi or Lo) is asserted (board in reset), and an external relay or switch is then used to un-assert the reset line when in transmit. Only one reset line should be used, and the unused line should be de-asserted.

The reset/overload state should be used when going from transmit to receive, as the modulator output will be turned off immediately upon entering the reset/overload state.

Configuring the Resets
Using Reset Hi: Install R736, R739 - low (0V) to xmit
Using Reset Lo: Install R737, R738 - high (+5) to xmit

To External Relays

Radio Engineering Associates

Efficiency Meter, Overload Detect

Steve Cloutier	Rev C - 2	Page 1 of 1
	1/2007	

Circuit & Methods Copyright 1998-2006 Radio Engineering Associates Inc. Use of this circuit by individuals for their own non-commercial use is permitted and encouraged. All other uses, reproduction, duplication, mass production or use for any commercial purpose is prohibited without written permission.
Patent Pending, US Patent & Trade Office.

700 - Efficiency Meter - Overload Detect - Board

Important: Observe polarity of small signal transistors Q701, 702, Q703, Q704, Q705, etc. Tab is emitter, (E-B-C). Some transistors may not line up with the board hole pattern or device layout. Transistor may need to be installed "backwards". Make sure the transistors are installed properly !!!

R736 to R739 - See Note before installing.